

JOINT ADMISSION TEST FOR M.Sc. 2018

JAM 2018

Admission to

M.Sc. (Two Years), Joint M.Sc.-Ph.D., M.Sc.-Ph.D. Dual Degree, and
other Post-Bachelor Degree Programmes

at

INDIAN INSTITUTES OF TECHNOLOGY

BHUBANESWAR • BOMBAY • DELHI • DHANBAD • GANDHINAGAR • GUWAHATI • HYDERABAD
INDORE • JODHPUR • KANPUR • KHARAGPUR • MADRAS • PATNA • ROORKEE • ROPAR

&

Integrated Ph.D. Programmes

at

INDIAN INSTITUTE OF SCIENCE, BANGALORE

INFORMATION BROCHURE

JAM 2018 Examination Date: February 11, 2018 (Sunday)

Organizing Institute



INDIAN INSTITUTE OF TECHNOLOGY BOMBAY
Mumbai - 400076



INDIAN INSTITUTE OF TECHNOLOGY BOMBAY



JAM 2018 Website:
<http://jam.iitb.ac.in>

JAM 2018: Highlights

- ➡ IIT Bombay is the Organizing Institute for JAM 2018.
- ➡ JAM 2018 Examination will be conducted **ONLINE only** as a Computer Based Test (CBT) for all Test Papers.
- ➡ All the seven Test Papers of JAM 2018 will be of fully **objective type**, with three different patterns of questions, namely (i) Multiple Choice Questions (MCQ), (ii) Multiple Select Questions (MSQ), and (iii) Numerical Answer Type (NAT) questions.
- ➡ Applications will be accepted **ONLINE only** through JAM 2018 website.
- ➡ No hardcopies of documents are to be sent to the Organizing Institute. The applicable documents are to be uploaded to the online application website only.
- ➡ Biometric system of verification (finger-print) will be used for JAM 2018 exam and admission.
- ➡ No hardcopy of JAM 2018 scorecard will be sent to the JAM 2018 qualified candidates by the Organizing Institute. **It can only be downloaded from JAM 2018 website within a specified period.**
- ➡ **No** additional requirements, like **suitability test** or **interview**, are needed for the programmes for which admission process is through JAM.
- ➡ **Integrated Ph.D. programmes** in Physical Sciences, Chemical Sciences, Mathematical Sciences & Biological Sciences at **IISc Bangalore** will use the **JAM results to shortlist the candidates for final selection.**

CONTENTS

Section	Title	Page
1.	Introduction	1
2.	General Information	1
3.	Academic Programmes	2
4.	Test Papers and Minimum Educational Qualifications (MEQs) for Admission	5
5.	Eligibility Requirements (ERs) for Admission	5
6.	Pattern of Test Papers	6
7.	Test Schedule and Application Fee	7
8.	Choice of Examination Cities	7
9.	Code of Conduct	8
10.	Reserved Seats	9
11.	How to Apply	10
	11.1 Application Procedure	10
	11.2 Photograph Requirements	11
	11.3 Signature Requirements	12
	11.4 Category Certificates	15
	11.4 Application Fee Payment Procedure	16
	11.5 Important Points to be Noted	17
	11.6 Application Scrutiny and Rectification	18
12.	Admit Card	18
13.	Rank and Merit List	19
	13.1 Rank List	19
	13.2 Merit List	19
14.	Admission Procedure	20
15.	Syllabi for Test Papers	22
	15.1 Biological Sciences (BL)	22
	15.2 Biotechnology (BT)	23
	15.3 Chemistry (CY)	24
	15.4 Geology (GG)	26
	15.5 Mathematics (MA)	27
	15.6 Mathematical Statistics (MS)	27
	15.7 Physics (PH)	28
Appendix-I	Academic Programmes (and their Codes) covered under JAM 2018 at various Institutes for JAM 2018 Qualified Candidates	31
Appendix-II	Test Papers, Corresponding Academic Programmes offered by the Admitting Institutes and their Minimum Educational Qualifications	35
Appendix-III	Examination Cities/Towns for JAM 2018	38
Appendix-IV	Authorities who can Issue SC/ST/OBC-NCL Certificates	39
Appendix-V	Proforma for OBC (Non-Creamy Layer) Certificate	40
	Important Dates and Contact Addresses for JAM 2018	41
	Contact details	42

1. INTRODUCTION

The Indian Institutes of Technology (IITs) are institutions of national importance established through an Act of Parliament. The Indian Institute of Science (IISc) is a premier research and teaching institute established in 1909. The IISc Bangalore & IITs are well known, the world over, for quality education in engineering, science, management and research in frontier areas. The aim of these institutes is to build a sound foundation of knowledge, pursue excellence and enhance creativity in an intellectually stimulating environment. The current pace of advancement of technology needs a coherent back-up of basic science education and research. The vibrant academic ambience and research infrastructure of IISc Bangalore & IITs motivate the students to pursue Research and Development careers in frontier areas of basic sciences as well as interdisciplinary areas of science and technology. Further, IISc and IITs have well equipped modern laboratories, efficient computer networks and state-of-the-art libraries. The teaching process is structured to promote close and continuous contact between the faculty and the students. A number of financial assistantships are available to SC/ST and other deserving and meritorious students at individual institutes.

From the Academic Session 2004-05, IITs started conducting a **Joint Admission Test for M.Sc. (JAM)**. The objective of JAM is to provide admissions to M.Sc. (Two Years), Joint M.Sc.-Ph.D., M.Sc.-Ph.D. Dual Degree, and other Post-Bachelor Degree Programmes at the IITs and the Integrated Ph.D. Degree Programmes at IISc and to consolidate Science as a career option for bright students from across the country. JAM is expected to serve as a benchmark for the undergraduate level science education in the country. The Integrated Ph.D. Programme at IISc was started in the early 1990's to enable students to directly join for a Ph.D. Degree after their B.Sc. Degree.

The M.Sc. (Two Years), Joint M.Sc.-Ph.D., M.Sc.-Ph.D. Dual Degree, and other Post-Bachelor's Degree Programmes at the IITs and the Integrated Ph.D. Programmes at IISc offer high quality education in their respective disciplines, comparable to the best in the world. The curricula for these programmes are designed to provide the students with opportunities to develop academic talent leading to challenging and rewarding professional life. The curricula are regularly updated at IISc and IITs. The interdisciplinary content of the curricula equips the students with the ability to utilize scientific knowledge for practical applications. The medium of instruction is English for all the above mentioned programmes.

2. GENERAL INFORMATION

- (a) JAM 2018 is open to all nationals (Indian/Foreign). Candidates seeking admission to the academic programmes covered under JAM 2018 need to appear in JAM 2018. There is no age restriction.
- (b) **JAM 2018 Examination will be held on February 11, 2018 (Sunday) as a Computer Based ONLINE Examination.**
- (c) For admission, foreign nationals are required to satisfy the rules and regulations of the Admitting Institute(s) pertaining to foreign students. For further details, they are advised to contact the concerned Admitting Institute(s).
- (d) To apply for admission to a desired programme, a candidate is required to qualify in the relevant Test Paper and also satisfy the Minimum Educational Qualifications (MEQs) and Eligibility Requirements (ERs) of the respective Academic Programme.

- (e) The candidates who have either appeared or are due to appear in the final examination of their qualifying degree in 2018 are also eligible to appear in JAM 2018. By qualifying in JAM 2018, candidates can apply for provisional admission subject to the condition that: (a) all parts of their final examination shall be completed by the date of registration of the Admitting Institute, and (b) proof of having passed the qualifying degree with required eligibility, as specified by the Admitting Institute, should be submitted by **September 30, 2018**.
- (f) On the basis of performance in JAM 2018, for each test paper, separate merit lists will be prepared for General (GEN), OBC Non-Creamy Layer (OBC-NCL), SC, ST, and Persons with Disability (PwD) category candidates.
- (g) Admission to most of the Academic Programmes at various institutes will be made on the basis of Rank in JAM 2018.
- (h) Requests for change of category, if any, with proper documentation, should reach the **Organizing Institute** latest by **May 07, 2018**. Requests received after this date will not be accepted under any circumstances.
- (i) **Candidates should note that mere appearance in JAM 2018 or being in the merit list of any test paper neither guarantees nor provides any automatic entitlement to admission.** Qualified candidates will have to apply for admission as per the prescribed procedure. Admissions shall be made in the order of merit in each category and depending on the number of seats available at the Admitting Institute(s).
- (j) The list of academic programmes, number of seats, eligibility requirements and minimum educational qualifications of each of the programmes mentioned in this Information Brochure are subject to change, as per the policy of Admitting Institute(s).
- (k) In this document, the phrases 'Un-Reserved' and 'General' are used interchangeably and they mean the same.
- (l) With regard to the interpretation of the provisions on any matter not covered in this Information Brochure, the decision of the **Organizing Institute** shall be final and binding on all the parties concerned.
- (m) In all matters concerning JAM 2018, the decision of the **Organizing Institute** or the **Organizing Chairman, JAM 2018** will be final and binding on all the applicants.
- (n) Although JAM 2018 is held at different centres across the country, **Indian Institute of Technology Bombay** is the **Organizing Institute**, and has the overall responsibility of conducting JAM 2018. In case of any claims or disputes arising in respect of JAM 2018, it is hereby made absolutely clear that the Mumbai High Court alone shall have the exclusive jurisdiction to entertain and settle any such disputes and claims.

3. ACADEMIC PROGRAMMES

The following are the full-time M.Sc. (Two Years), Joint M.Sc.-Ph.D., M.Sc.-Ph.D. Dual Degree, and other Post-Bachelor's Degree Programmes at different IITs and Integrated Ph.D. Programmes at IISc to which admissions shall be made on the basis of JAM 2018.

- i. **Indian Institute of Science, Bangalore (IISc):** Integrated Ph.D. Programmes in Biological Sciences, Chemical Sciences, Mathematical Sciences, and Physical Sciences

- ii. **IIT Bhubaneswar (IITBBS):** Joint M.Sc.-Ph.D. Programmes in (i) Chemistry, (ii) Geology, (iii) Mathematics, (iv) Physics, and (v) Atmosphere and Ocean Sciences

The modalities for selection to the Ph.D. programme in the joint M.Sc. - Ph.D. programme are as follows.

After completing the third semester of the M.Sc. Programme:

(a) Those students securing CGPA ≥ 8.5 and having expressed their desire to continue in writing are eligible to opt for the Ph.D. Programme. Final selection will be based on the written test, interview and other short listing criteria set by the Institute. Those not selected and those who do not opt for the Ph.D. Programme will exit with an M.Sc. Degree.

(b) Those with CGPA < 8.5 are not allowed to opt for the Ph.D. Programme and will exit with an M.Sc. degree.

- iii. **IIT Bombay (IITB):** Two-year Master of Science (M.Sc.) Programmes in (i) Applied Geology, (ii) Applied Geophysics, (iii) Applied Statistics and Informatics, (iv) Biotechnology, (v) Chemistry, (vi) Mathematics, and (vii) Physics

M.Sc.-Ph.D. Dual Degree Programmes in (i) Environmental Science and Engineering, (ii) Operations Research. Both the degrees will be awarded together after the successful completion of the Programmes.

- iv. **IIT Delhi (IITD):** Two-year Master of Science (M.Sc.) Programmes in (i) Chemistry, (ii) Mathematics, and (iii) Physics

- v. **IIT Dhanbad (ISM):** Two-year Master of Science (M.Sc.) Programmes in (i) Chemistry, (ii) Mathematics and Computing, (iii) Physics, and Three year Master in Science (M.Sc.[Tech]) in (i) Applied Geology, and (ii) Applied Geophysics

- vi. **IIT Gandhinagar (IITGN):** Two-year Master of Science (M.Sc.) Programmes in (i) Chemistry, (ii) Mathematics, and (iii) Physics

- vii. **IIT Guwahati (IITG):** Two-year Master of Science (M.Sc.) Programmes in (i) Chemistry, (ii) Mathematics and Computing, and (iii) Physics

- viii. **IIT Hyderabad (IITH):** Two-year Master of Science (M.Sc.) Programmes in (i) Chemistry, (ii) Mathematics/ Mathematics and Computing, and (iii) Physics

- ix. **IIT Indore (IITI):** Two-year Master of Science (M.Sc.) Programmes in (i) Chemistry, (ii) Mathematics, (iii) Physics, and (iv) Biotechnology, and (v) Astronomy with an option to convert it to M.Sc.-Ph.D. Dual Degree Programme during second semester. Programme conversion of the eligible students is confirmed at the end of the third semester subjected to them qualifying the CSIR/UGC-NET, GATE or any equivalent examination and meeting the short-listing criteria of the concerned discipline. Students continuing M.Sc.-Ph.D. Dual Degree Programme are awarded M.Sc. degree after successful completion of all its prescribed requirements with recognition that it also partially fulfills the requirements of M.Sc. and Ph.D. Dual Degree Programme.

- x. **IIT Jodhpur (IITJ):** Two-year Master of Science (M.Sc.) Programmes in (i) Chemistry, (ii) Mathematics, and (iii) Physics

- xi. **IIT Kanpur (IITK):** Two-year Master of Science (M.Sc.) Programmes in (i) Chemistry, (ii) Mathematics, (iii) Physics, and (iv) Statistics

M.Sc.-Ph.D. Dual Degree Programme in Physics (Transfer from M.Sc.-Ph.D. Dual Degree Programme to M.Sc. Physics Programme is not permitted. However, for the students admitted to the M.Sc.-Ph.D. Dual Degree Programme, the M.Sc. degree

will be given after successful completion of all academic requirements of the first six semesters while working towards Ph.D. degree).

- xii. IIT Kharagpur (IITKGP):** Joint M.Sc.-Ph.D. Programmes in (i) Chemistry, (ii) Geology, (iii) Geophysics, (iv) Mathematics, and (v) Physics
- xiii. IIT Madras (IITM):** Two-year Master of Science (M.Sc.) Programmes in (i) Chemistry, (ii) Mathematics, and (iii) Physics
- xiv. IIT Patna (IITP):** Two-year Master of Science (M.Sc.) Programmes in (i) Chemistry, (ii) Mathematics, and (iii) Physics
- xv. IIT Roorkee (IITR):** Two-year Master of Science (M.Sc.) Programmes in (i) Applied Geology, (ii) Biotechnology, (iii) Chemistry, (iv) Economics, (v) Mathematics, and (vi) Physics
- xvi. IIT Ropar (IITRPR):** Two-year Master of Science (M.Sc.) Programmes in (i) Chemistry, (ii) Mathematics, and (iii) Physics

The academic programmes, their durations and number of seats available in various institutes with programme codes are listed in **Appendix-I**.

The profile of the admitting institutes covered under JAM 2018 can be seen at the websites of the respective institutions as given in Table 1.

Table 1: Website Addresses

S.No.	Name of Institute	Website
1	IISc Bangalore	www.iisc.ernet.in
2	IIT Bhubaneswar	www.iitbbs.ac.in
3	IIT Bombay	www.iitb.ac.in
4	IIT Delhi	www.iitd.ac.in
5	IIT (ISM) Dhanbad	www.iitism.ac.in
6	IIT Gandhinagar	www.iitgn.ac.in
7	IIT Guwahati	www.iitg.ernet.in
8	IIT Hyderabad	www.iith.ac.in
9	IIT Indore	www.iiti.ac.in
10	IIT Jodhpur	www.iitj.ac.in
11	IIT Kanpur	www.iitk.ac.in
12	IIT Kharagpur	www.iitkgp.ac.in
13	IIT Madras	www.iitm.ac.in
14	IIT Patna	www.iitp.ac.in
15	IIT Roorkee	www.iitr.ac.in
16	IIT Ropar	www.iitrpr.ac.in

4. TEST PAPERS AND MINIMUM EDUCATIONAL QUALIFICATIONS (MEQs) FOR ADMISSION

JAM 2018 Examination will be conducted in seven subjects, also referred to as Test Papers; Biological Sciences (BL), Biotechnology (BT), Chemistry (CY), Geology (GG), Mathematics (MA), Mathematical Statistics (MS) and Physics (PH). Candidates are advised to become familiar with the code(s) of the test paper(s) that they wish to appear as this information is required at the time of application form submission, at the time of examination, and later at the time of admission process.

The Minimum Educational Qualifications (MEQs) for admissions to various Academic Programmes covered under JAM 2018 are given in **Appendix-II**, along with the names of the Test Papers with their Codes and the Institute offering the Academic Programmes. Admission to each of the Academic Programmes shall be offered on the basis of merit in the corresponding Test Paper(s) of JAM 2018.

5. ELIGIBILITY REQUIREMENTS (ERs) FOR ADMISSION

The candidates who qualify in JAM 2018 shall have to fulfill the following Eligibility Requirements (ER) for admissions in IITs.

- All candidates admitted through JAM should have a Bachelor's degree.
- In the qualifying degree, the aggregate marks or CGPA/CPI **without rounding-off** (taking into account all subjects, including languages and subsidiaries, all years combined) should be at least 55% or 5.5 out of 10 for General/OBC (NCL) category candidates and 50% or 5.0 out of 10 for SC/ST and PwD category candidates.

For Candidates with letter grades/CGPA (instead of percentage of marks), the equivalence in percentage of marks will be decided by the Admitting Institute(s).

Proof of having passed the Qualifying Degree with the Minimum Educational Qualifications (MEQ) as specified by the Admitting Institute should be submitted by **September 30, 2018**.

At the time of admission, all admitted candidates will have to submit a physical fitness certificate from a registered medical practitioner in the prescribed form. At the time of admission, the admitted candidates may also have to undergo a physical fitness test by a medical board constituted by the Admitting Institute. In case a candidate is not found physically fit to pursue his/her chosen course of study, his/her admission is liable to be cancelled.

Note:

- (a) It will entirely be the responsibility of the Candidate to prove that he/she satisfies the Minimum Educational Qualifications (MEQs) and Eligibility Requirements (ERs) for Admission.**
- (b) The Admitting Institute has the right to cancel, at any stage, the admission of a candidate who is found to have been admitted to a course to which he/she is not entitled, being unqualified or ineligible in accordance with the rules and regulations in force.**

However, because of operational constraints, the JAM 2018 Committee reserves the right to add a new city or remove an existing one, and allot a city that may not be any one of the choices stated by the candidate.

An examination city may have one or more examination centres. A centre once allotted will not normally be changed. A request for change of a centre within the same City/Town will **NOT** be permitted. In exceptional circumstances, a change of examination City/Town may be permitted, if a request with a valid reason for the same is received in the office of the Organizing Chairman, JAM 2018, IIT Bombay, Mumbai 400076, on or before **October 30, 2017**, along with a Demand Draft of Rs. 500/- drawn in favour of “**The Registrar IIT Bombay**”, on any Nationalized Bank, payable at Mumbai. **Please note that payment of Rs. 500/- does not necessarily guarantee the change of centre.** The decision of the Organizing Chairman, JAM 2018, in this regard will be final.

9. CODE OF CONDUCT

All candidates appearing for the JAM 2018 Examination must comply strictly with the following Rules and Regulations:

- Candidates appearing for JAM 2018 examination must carry their Admit Card and original valid photo-identity proof to the examination hall.
- Biometric system of verification will be used. The candidate's finger-print will be captured before he/she takes the JAM 2018 exam. This captured data will be used for verification during the admission process. Hence, you should avoid any coating (ink, mehendi, henna, or tattoo) on your fingertips and have clean fingers on the examination day.
- Scribble pads will be provided to candidates in the examination hall by the invigilators. The same should be used for all rough work. Candidates should write their name and registration number on the scribble pads. The scribble pads must be returned to the invigilators after the end of the examination.
- Carrying of mobile phones (even in the switched-off mode), smart watches and calculators inside the examination hall is strictly prohibited.
- Carrying of any other electronic devices that can be used for communication or for any other purpose, and printed or hand-written materials, inside the examination hall is strictly prohibited.
- All means of communication (verbal or otherwise) among the candidates inside the examination hall are strictly prohibited.
- Candidates should not tamper with the computer and the related hardware provided in the examination hall. Candidates found to have tampered with these willfully, will have their candidature cancelled summarily. In addition, appropriate legal action will be initiated against such candidates.

The JAM 2018 candidature of candidates found using unfair means and not in line with the code and ethics of the JAM Examination may be cancelled. Their Test Paper(s) will not be evaluated, even if they may have been allowed to complete their examination. In addition, appropriate legal action may be initiated against all such candidates.

10. RESERVED SEATS

In every programme, a certain number of seats are reserved for candidates belonging to various categories. The number of seats reserved under various categories in each of the programmes covered under JAM 2018 is given in **Appendix-I**. The category-wise list in a JAM paper will be prepared based on the category declared by the candidate in the application form. The final seat allotment will be done based on a valid Category Certificate (in the prescribed format) submitted along with the Application Form for Admission.

A candidate who seeks admission under SC/ST/OBC-NCL category must submit, along with the filled-in Application Form for Admission, the requisite certificate issued by a competent authority as specified in **Appendix-IV**, failing which his/her candidature for admission will not be considered under the reserved category.

A candidate who seeks admission under the OBC-NCL Category must submit an OBC-NCL Certificate in the format shown in **Appendix-V** along with the filled-in Application Form for admission. **The candidate will be considered in the General Category in case the OBC-NCL Certificate is not in the prescribed format or he/she has submitted an invalid certificate and no opportunity will be given to the candidate for late submission of the said certificate under any circumstances.**

For PwD candidates with any category of disability (viz., blindness or low vision, hearing impairment, loco-motor disability, and/or cerebral palsy), benefit will be given to only those who have at least **40%** permanent physical impairment with respect to a body part/ system/extremity/ whole body, etc. Such candidates must submit, along with the filled-in Application Form, the Certificate of Disability from a Government Medical Board and should be fit to pursue the Programme. The disability percentage of candidates selected for admission under PwD category may also be required to be certified by a Medical Board, duly constituted by the Admitting Institute. *The JAM Organizing Institute will not be responsible for any incorrect declaration of the PwD status of candidates. JAM 2018 will follow the guidelines as mentioned in the government regulations.*

Please refer to <http://www.ccdisabilities.nic.in/content/en/docs/omguide.pdf> and <http://www.ccdisabilities.nic.in/content/en/docs/CCDLetters.pdf>. The facility of scribe is meant for only those PwD candidates who have physical limitation to write including that of speed. Please refer to <http://www.ccdisabilities.nic.in/content/en/docs/CCDLetters.pdf> (in particular to the fifth page of the document) for the clarification issued by CCPD on 18.03.2013. The additional time would be applicable only to such candidates. Furthermore, Visually challenged PwD candidates may contact the JAM-Institute representative through the invigilator in the examination hall for “magnified/large font question paper”.

Note:

- (a) **The provisions for the reserved seats given in Appendix-I are subject to modification in accordance with any Government Order, if issued subsequently by the Government of India.**
- (b) **It will entirely be the responsibility of a candidate to prove his/her eligibility for admission in terms of Minimum Educational Qualifications (MEQ), etc., and for claiming reservation under a specific category.**

11. HOW TO APPLY

11.1 Application Procedure

Candidates can apply for JAM 2018 only through JAM Online Application Processing System (JOAPS) link available at website <http://jam.iitb.ac.in>. The facility for Online Registration and Application will be available through the website <http://jam.iitb.ac.in> from **September 05, 2017**. A candidate has to first register on JOAPS website, by providing his/her **name, a valid E-mail address, a working mobile number and a password**. The candidate must give an E-mail address that he/she uses and checks frequently, as all communications to the candidate from JAM 2018 will be sent to this E-mail address. The candidate must not use somebody else's E-mail address and **only one candidate can be registered with one E-mail address**. Similarly, the candidate should provide his/her personal mobile number because most of the communications may also be sent via SMS. The password that the candidate provides should be chosen so that it cannot be guessed easily by others and this password must not be forgotten by the candidate as he/she will require it to login to the online application website. Upon successful registration, an E-mail containing candidate's Enrolment ID will be sent to the E-mail address provided by the candidate. The Enrolment ID will also be sent to the mobile number provided by the candidate. The candidate needs to use this enrolment ID along with the password for all JAM 2018 related communications or website operations. **Keep your ID along with the password information safe and confidential.**

JOAPS provides an online interface to the candidate for interacting with the JAM Administration. With this interface, a candidate can:

- Apply for the examination online.
- Upload photograph, signature and other documents like category certificate (if applicable), PwD certificate (if applicable), etc.
- Pay the application fee through any of the electronic payment modes.
- Check the Status of the application form: Received, Under scrutiny, Accepted, Defect status, Status after rectification, Rejected with valid reasons, Admit card ready for download, etc.
- Download Admit Card.
- View your answers, marks and JAM score.
- Download JAM scorecard.
- Submission of application for Admission

Candidates are discouraged from making application through a third person. If someone else (friend or Internet café person) is filling the application on behalf of the candidate, the candidate must ensure that the data submitted are correct. It has been noticed during earlier occasions that the information filled by other person on behalf of the candidate was wrong, since they did not have correct information about the candidate. Hence, we strongly discourage such practice while filling the online application form.

Data Requirement for Filling the Application form: The following data will be required while filling the form at JOAPS:

- Personal information (name, date of birth, personal mobile number, parents' name, parents' mobile number, etc.). Please note that the name of the candidate in the application form must exactly be the same as per the qualifying degree certificate. JAM 2018 Score Card will be issued as per the name entered in the application form. Prefix/title such as Mr/Shri/Dr/Mrs/Smt, etc. should NOT be used before name.
- Address for Communication (including PIN code)
- Eligibility degree details
- College name and address with PIN code
- JAM paper/s
- Choice of JAM Examination cities
- High-quality image of candidate's photograph conforming to the requirements specified
- Good-quality image of candidate's signature conforming to the requirements specified
- Scanned copy of Category (SC/ST) Certificate (if applicable) in pdf format
- Scanned copy of PwD Certificate (if applicable) in pdf format
- Details of the valid Identity Document (ID) (This ID proof, in original, should be carried by the candidate to the examination hall)
- Net-banking/debit card/credit card details for fee payment

The JOAPS allows you to enter the data, "Save" partially filled form, "Logout", and "Resume Filling" by logging in again. The JOAPS portal is self-explanatory and user-friendly. Additional help information required in filling various fields in the JOAPS portal will be made available.

Upon logging into the JAM 2018 application processing website, the candidate needs to fill in information, such as parent/guardian's name and mobile number, city choices, the number and choice of test paper(s) that he/she wishes to appear, date of birth, gender, address for communication, category and PwD status. The candidate's application fee will get determined based on this information. The candidate should also fill his/her other details, such as information on qualifying degree, percentage of marks/CGPA, details of valid personal ID information, etc. It may be noted that the candidate can specify any one of the following photo ID cards for the personal ID information: Aadhaar ID, College ID, Driving License, Employee ID, PAN Card, Passport, or Voter ID.

The JAM 2018 application requires that your photograph and signature are uploaded electronically at JOAPS. *Uploading photograph and signature that does not meet the specifications can result in disqualification of the application without any refund of the application fee.*

11.2 Photograph Requirements

- **Please pay attention to upload only good quality photograph. The JAM Score Card will be printed with the photograph you submit.**

- **The photograph must match with your appearance on the day of the examination.**
- A passport size (3.5 cm Width × 4.5 cm Height) photograph of the face of the candidate is required for application form.
- The photograph must be in **COLOR** and taken **after 01 August 2017** in a professional studio. Photographs taken using a mobile phone and other self-composed portraits may result in the rejection of application.
- Request photo studio to provide the image of your photo in a JPEG format and also on a standard 3.5 cm × 4.5 cm (Width × Height) print.
- **Maximum size of the JPEG image can be 480×640 in pixels (0.3 Mega pixel) (Request photo studio to reduce it to this size if it is larger).** Minimum pixel size of the JPEG image can be 240×320. File size of the image should be in the range of 5KB to 200KB.
- Background of the photograph must be **white** or a *very light colour*.
- The face should occupy at least 50% of the area of the photograph with a full-face view looking into the camera directly.
- The main features of the face must not be covered by hair of the head, any cloth or any shadow. Forehead, eyes, nose and chin should be clearly visible.
- If you normally wear spectacles, a photograph with glare on glasses is not acceptable in your photo. While you may wear spectacles for the photo shoot, **if glare cannot be avoided**, then remove the spectacles.
- **You must not wear spectacles with dark or tinted glasses, only clear glasses are permitted.**
- Poor quality of the photograph submitted will lead to rejection of your JAM application, without any refund of the application fee.

Table 4 shows samples of acceptable good-quality photographs and poor-quality unacceptable photographs

11.3 Signature Requirements

- Please draw a rectangular box of size 2 cm × 7 cm (Height × Width) on an A4 white paper. Sign with black or dark blue ink pen within this box.
- The signature with all CAPITAL LETTERS, Initials or in any other colour (other than black and blue) shall NOT be accepted.
- Get the digital image of the rectangular box (with your signature inside) scanned by using a professional scanner. Crop it to the border of the box. Table 5 shows sample signatures that are acceptable and unacceptable.
- Only JPEG image format will be accepted.
- The maximum image size of the signature can be 160×560 in pixels.
- The minimum image size of the signature can be 80×280 in pixels.
- File size of the image should be in the range of 5KB to 100KB.

Table 4: Sample Photographs

A: Sample Photographs - Accepted



B. Sample Photographs - Rejected

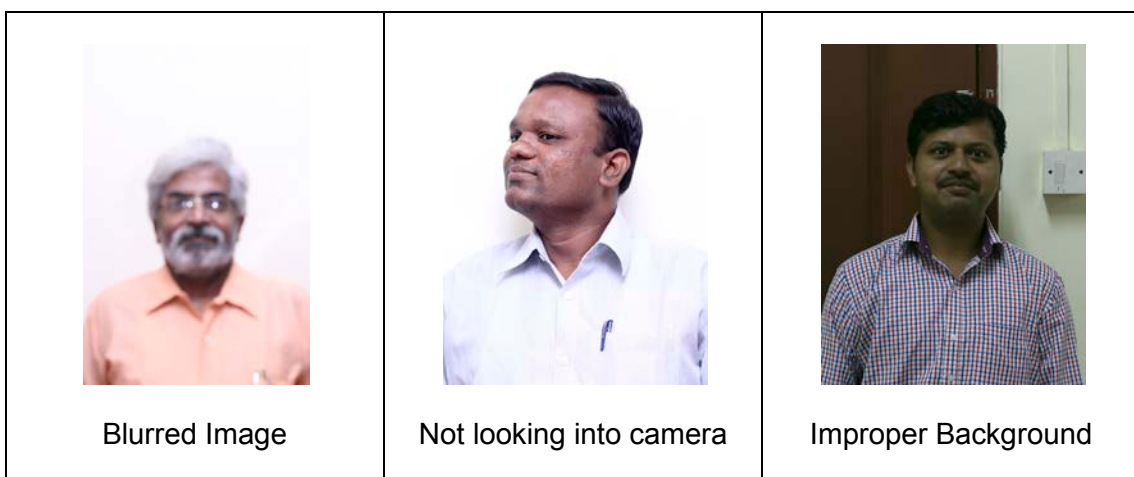

Sample Photographs - Rejected

 <p>Smaller in Size (Standard size is 3.5 cm x 4.5 cm)</p>	 <p>Shadow on the face</p>	 <p>Photo taken from mobile</p>
 <p>Face covered with cloth</p>	 <p>Glare on spectacles</p>	 <p>Wearing Colored glasses</p>
 <p>Side view</p>	 <p>Cropped from other Photo</p>	 <p>Face not covering 50% area</p>

Table 5: Sample Signatures

Acceptable Signatures

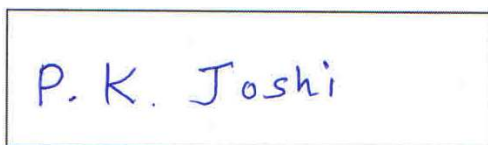

P. K. Joshi

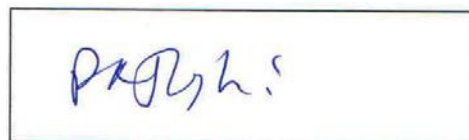

PKJoshi

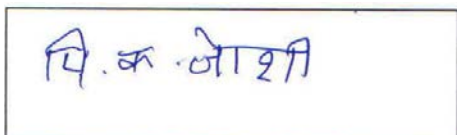

पि.क. जोशी



PKJoshi

Unacceptable Signatures

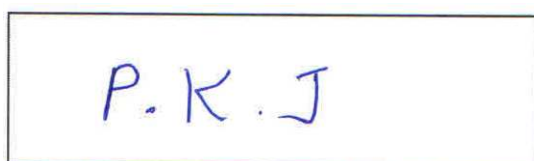

P. K. J

Signature in Initial

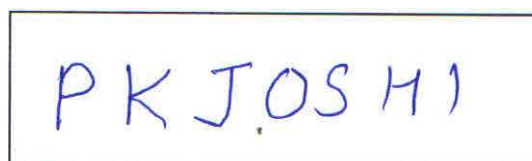

PKJOSHI

Signature in ALL CAPITAL

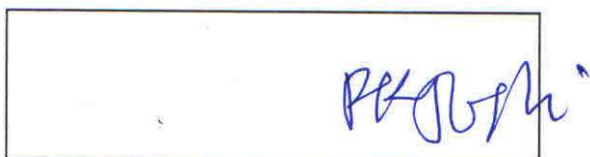

PKJoshi

Signature outside the rectangle

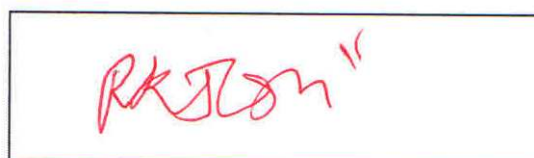

PKJoshi

Signature in other than blue or black ink

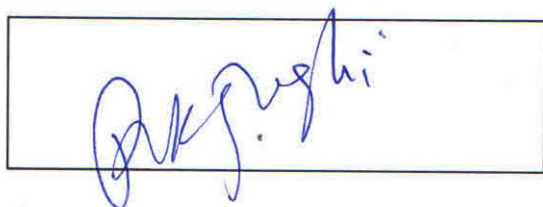

PKJoshi

Signature outside the rectangle



PKJoshi

Signature is too small to view

11.4 Category Certificate

Candidates who belong to SC or ST category have to upload a valid documentary proof for concession in application fees. Certificate issued ONLY by authorized officials (**Appendix-V**) shall be valid. Necessary actions shall be initiated for any wrong doing and misinformation. The same document shall be required to be submitted to the Admitting Institute at the time of admission. The onus of verifying SC/ST certificate lies with the Admitting Institute. The JAM Committee will not be responsible for any incorrect declaration of the SC/ST status of candidates.

Person with Disability (PwD) Certificate: In order to avail application fee concession under the Person with Disability (PwD) category, the candidates should attach a recently obtained valid PwD certificate issued by the competent authority. The same document shall be required to be submitted to the Admitting Institution at the time of admission. The onus of verifying PwD certificate lies with the Admitting Institute. The JAM Committee will not be responsible for any incorrect declaration of the PwD status of candidates.

NOTE to OBC-NCL Candidates: OBC-NCL candidates are NOT required to submit/upload any category certificate along with the filled online application form. However, they are required to submit this certificate in the prescribed format (Appendix-V) at a later date.

After filling in the required fields in the application form and uploading the required documents, the candidate must review his/her complete application form before final submission and making payment.

The last date to complete and submit the application form is October 10, 2017 (Tuesday).

Any application that is incomplete in any respect and does not have the required valid applicable documents will be summarily rejected. The candidates must take care to fill in the details in the application form correctly and must upload the correct and valid documents, including signatures and photographs.

The candidates are advised to visit the '[FAQ](#)' section as well for additional queries.

11.5 Application Fee Payment Procedure

The application fee as shown in Table 6 is to be paid **online** only. The candidate will be able to make the payment using his/her net-banking account, debit or credit card until **October 10, 2017**. Additional bank charges may apply for the transaction depending on the payment option. This charge will be specified on the payment portal. Before proceeding for making any payment applicant should view his application by clicking the "**Save and Preview**" button. They should go through the application and ensure that there is no error in the application form and all the relevant and valid documents are uploaded. If there are any corrections, they can go back and do the correction. After this they should click on "**Proceed for Payment**" button. Once a candidate presses "**Proceed for Payment**" button, **NO FURTHER CHANGES** in the application form can be made and the candidate will be directed to the payment portal. On the fee payment portal, the fee amount and bank charges will be shown and the candidate has to confirm that the payment is for JAM 2018. Once confirmed and payment is successful, the candidate will be redirected back to the JAM Online Application Website, where it shows confirmation of the fee payment. If you had selected only ONE Paper there will be an option to choose a second paper. If you desire to do so, you can proceed by paying the additional amount as indicated.

If a candidate has difficulty making the payment (due to internet connection or power failure, for example) or is not sure whether payment has been processed or not, then they should login back to JOAPS website after one-hour and check the status of the payment. If status is "**Fee Pending/Not Paid**" then initiate a fresh online payment through JOAPS fee payment portal. Otherwise the application will be rejected due to non-payment of the application fee in time. In case, the fee amount has been debited from your bank account, but JOAPS does not acknowledge any fee payment, then the money will be credited back to your account within seven working days.

Table 6: Application Fee Details for JAM 2018

Group/Category	One Test Paper	Two Test Papers
Female (All Categories)/ SC/ST/PwD	Rs. 750/-	Rs. 1050/-
All Others	Rs. 1500/-	Rs. 2100/-

11.6 Important Points to be Noted

- An application once submitted Can Not be changed/rectified. Therefore, before submitting the JAM 2018 application, please ensure that all the details and all the necessary supporting documents are filled/uploaded and there is NO error.
- Please, also ensure to pay the application fee as per the gender/category and test paper option. If the fee paid is NOT as per the Gender and Category, and the number of Test Paper(s), entered in the Application Form, then the filled in form will be rejected without any intimation to the candidate.
- Multiple applications submitted by a candidate are liable for rejection. Hence, DO NOT submit multiple application forms. After submitting an application, if a candidate decided to appear in other test paper or to change test paper(s), he/she can ADD THE ADDITIONAL TEST PAPER or can change the TEST PAPER(S) before the closing date in the earlier submitted application form. In such cases the candidate has to pay an additional fee online before closing date as per the Table 7.

Table 7: Additional Fee for Addition or Change of Test Paper(s)

Group/Category	Existing	Wishes to Change		Wishes to Add	
		Case	Additional Fee(Rs.)	Case	Additional Fee (Rs.)
Female (All Categories)/ SC/ST/PwD	One Test Paper	One Test Paper	Rs. 750/-	One Test Paper	Rs. 300/-
	Two Test Papers	Any One Test Paper	Rs. 300/-	Not Applicable	
		Both Papers	Rs. 1050/-		
All Others	One Test Paper	One Test Paper	Rs. 1500/-	One Test Paper	Rs. 600/-
	Two Test Papers	Any One Test Paper	Rs. 600/-	Not Applicable	
		Both Papers	Rs. 2100/-		

- The current status of an application will be updated after the scrutiny of the application. The status of an application can be checked anytime by logging into JOAPS.

Table 8: Additional Fee for Changing Category or Gender

Existing Gender/Category	Changes	Case	Additional Fee
Female (All Categories)/SC/ST/PwD (Group - 1)	Within Group-1	One or Two Test Paper(s)	NIL
	To Group-2	One Test Paper	Rs. 750/-
		Both Papers	Rs. 1050/-
All Others (Group - 2)	To Group-1	One or Two Test Paper(s)	NIL*

* No fee will be refunded in this case

- **Candidates, who have wrongly entered the Category or Gender will be allowed to change the Category or Gender with an additional fee as per Table 8. All these candidates are requested to pay the additional fee by Demand Draft (DD) drawn in favour of “The Registrar IIT Bombay”, on any nationalized bank, payable at Mumbai. The DD must be sent along with a request letter to "The Chairperson, JAM-2018, GATE-JAM Office, IIT Bombay, Powai, Mumbai-400076, on or before October 30, 2017.**
- **Please, contact JAM office in case of any queries/problems in filling application form and making fee payment online.**

11.7 Application Scrutiny and Rectification

All the applications submitted for JAM 2018 Examination shall be scrutinized to verify the accuracy of the data entered by the candidate with the submitted supporting documents and clarity of the photograph, signature, and relevant supporting documents. If everything is found to be in order, the application will be accepted. Otherwise, defects in the application will be marked and intimated to the candidate for rectification within a stipulated time period. The status of the application and defects marked in the application will be intimated to the candidates by E-mail and/or SMS. The current status of an application will be updated after the receipt and scrutiny of the application. The status of your application can be checked anytime by logging into JOAPS.

Candidates should act quickly in rectifying marked defects in the application at the earliest and definitely before the stipulated deadline. **Failing to rectify the defects within the stipulated time can lead to the application being rejected and no further communication will be entertained in this regard.**

12. ADMIT CARD

An Admit Card, bearing the Candidate's Name, Registration Number, Photograph, Signature and Name(s) and Code(s) of the Test Paper(s) applied along with the Name and Address of the Test Centre allotted, will be available for download from JOAPS website from **January 9, 2018** until **Examination Date**. Admit Cards will not be sent by post/E-mail. The Candidate should carefully examine the Admit Card for all the entries made therein. In case of any discrepancy, the Candidate should inform the Organizing

Chairperson, JAM 2018, IIT Bombay immediately. If a candidate is not able to download his/her Admit Card, then the Chairman JAM of the respective IISc/IITs (see [Appendix III](#)), under which the first choice Test City/Town of the candidate falls, may be contacted through Phone/Fax/E-mail, and provide the Online Enrolment ID, Name, E-mail ID, Mobile Number, Mailing Address and City Code of the desired Test Centre (first choice) to get information about the Registration Number and the Name of the Test Centre allotted.

A printout of the downloaded Admit Card must be brought to the Test Centre along with the original and valid photo identification. Please note that you have to give the details of this ID proof while filling the online application. No candidate will be permitted to appear in JAM 2018 examination without a valid Admit Card, and a valid and original ID. The Admit Card should be presented to the invigilators/JAM officials for verification.

The Admit Card of JAM 2018 must be carefully preserved by the Candidate and produced at the time of admission, if required by the Admitting Institute.

The Organizing Institute may withdraw the permission granted to a candidate to appear in JAM 2018, if it is found later on that the candidate is not eligible to appear in the exam, even though an Admit Card has been issued and is produced by the candidate before the Presiding Officer of the Test Centre.

13. RANK AND MERIT LIST

13.1 Rank List

For each test paper in JAM 2018, an All India Rank (AIR) will be assigned to all the appeared candidates based on the performance of the candidates in the test paper.

Tie-Breaking: The tie-breaking criterion for awarding the ranks to candidates scoring the same aggregate marks in a test paper will be as follows:

The candidate with a higher ratio of positive marks to negative marks will be given a higher rank. If this criterion fails to break ties, the concerned candidates will be awarded the same rank.

13.2 Merit List

The results (merit lists) will be declared on **March 20, 2018 (Tuesday)**. The results will be available on the website: <http://jam.iitb.ac.in>.

For each test paper, an All India Merit list will be prepared based on AIR. The number of candidates included in the All India Merit List will depend on the total number of seats available in each category (OBC-NCL, SC,ST, and PwD) in a given subject. These candidates (henceforth called Qualified Candidates) are eligible to apply for admission to any of the corresponding academic programmes available at IITs and IISc (see [Appendix-I](#)) Please note that the number of category-wise (OBC-NCL, SC, ST, and PwD) candidates included in the All India Merit List will be based on the category declared by the candidates in their application.

The **Score Card (indicating the All India Rank(s) and the mark(s) obtained by the candidate)** will be available for download from the JAM 2018 website from **March 27, 2018 to July 31, 2018** for qualified candidates.

14 ADMISSION PROCEDURE

Only candidates who **qualify** in JAM 2018 (whose names appear in the Merit List) will be eligible to apply for admission to any of the corresponding academic programmes available at IITs (refer to **Appendices-I & II** of this Information Brochure). Candidates are advised, in their own interest, to refer to the brief profiles of the Admitting Institutes and Departments at their respective websites (Table 1). Applicants should note that they have to apply for admission by filling an online Application Form for Admission (henceforth called Admission Form) available only at JAM 2018 website. Based on the test paper(s) qualified, an applicant can apply to one or more academic programmes covered under that test paper(s), subject to fulfillment of the Minimum Educational Qualifications (MEQs) and the Eligibility Requirements (ERs) of the Admitting Institutes. For the academic session 2018-19, the following admission procedure shall be followed for all the Programmes at IITs covered under JAM 2018. Candidates are also advised to refer to the JAM 2018 website for latest updates.

After JAM 2018 results are announced, a qualified candidate will have to apply ONLINE only using the prescribed Admission Form available at JAM 2018 website <http://jam.iitb.ac.in>, irrespective of IITs where the admission is sought. The period for online Admission Form submission is April 03-17, 2018.

NOTE to OBC-NCL Candidates: The candidates must upload a valid OBC-NCL certificate issued after 31st March 2017, in the prescribed format when they submit their application form for admission after the declaration of JAM 2018 results. The final seat allotment will be done based on the OBC-NCL certificate submitted along with the application form for admission. The candidate will be considered in the General category in case the OBC-NCL Certificate is invalid or not in the prescribed format or not uploaded within prescribed time.

- a) Irrespective of whether a candidate has qualified in one or two Test Papers, **only one** duly completed Admission Form should be submitted; listing, in an option form, all the programmes at IITs (along with the order of preferences) where the candidate is seeking admission.
- b) Upon logging into the JAM Online Application Process System website (JOAPS), the candidate needs to fill in the required information, such as choice of the programmes in order of preference, educational qualifications, percentage of marks/CGPA, category, PwD status, etc. After carefully choosing the order of programme preferences based on the ER and MEQ of the programmes at Admitting Institutes, a payment of Rs 600/- (Rupees six hundred only) is to be made as non-refundable processing fee. The payment can be made online through JOAPS latest by April 19, 2018 (Thursday).
- c) The Admission Form will not be considered if it is found incomplete in any respect or if it is not accompanied by the payment and the candidate will not be considered for admission, irrespective of satisfying the ER and MEQ of any programme(s) for which the Admission Form has been submitted. Also, a candidate will be considered for admission only to the programme(s), given in his/her Admission Form.
- d) Taking into consideration the order of preference as given in the Admission Form and corresponding rank(s) in the Merit List, the **First Admission List** for each programme under JAM 2018 will be prepared by the Organizing Institute and will be announced on **May 22, 2018 (Tuesday)** on JAM 2018 website.

Note: Applicants are requested to periodically check the website for knowing the status of the application/any communication. They should also check the messages sent to their registered email and mobile.

- e) After the declaration of the First Admission List, admission intimation will be sent by the Organizing Institute to the concerned candidates. Along with the submission of the acceptance form, these candidates will also have to pay an advance seat booking fee (Rs. 10000/- for General/OBC-NCL category candidates and Rs. 5000/- for SC/ST/PwD category candidates) online through JOAPS, within the deadline mentioned in the intimation. This amount will be transferred to the Admitting Institute and it will be adjusted against the Institute Fee at the time of Registration.
- f) If seats remain vacant after the first admission process is over, the Organizing Institute will prepare a **Second Admission List**. This second list will be announced by the Organizing Institute on **June 12, 2018 (Tuesday)** on JAM 2018 website and the intimation based on the second list, if any, will be sent by the Organizing Institute to the candidates concerned.
- g) Candidates who have been intimated about the offer through the Second List but not through the First List, must submit their acceptance form, along with an advance seat booking fee (Rs. 10000/- for General/OBC-NCL category candidates and Rs. 5000/- for SC/ST/PwD category candidates) paid online through JOAPS, within the deadline mentioned in the intimation. This amount will be transferred to the Admitting Institute and it will be adjusted against the Institute Fee at the time of Registration.
- h) If seats remain vacant even after the second admission process is over, the Organizing Institute will prepare a **Third and Final Admission List**. This third and final list will be announced by the Organizing Institute on **June 29, 2018 (Friday)** on JAM 2018 website and the intimation will be sent by the Organizing Institute to the candidates concerned.
- i) Candidates who have been intimated about the offer through the Third List but not through the First two Lists, must submit their acceptance form, along with an advance seat booking fee (Rs. 10000/- for General/OBC-NCL category candidates and Rs. 5000/- for SC/ST/PwD category candidates) paid online through JOAPS, within the deadline mentioned in the intimation. This amount will be transferred to the Admitting Institute and it will be adjusted against the Institute Fee at the time of Registration.
- j) **With the Third and Final Admission List, the admission process based on JAM 2018 will come to a close.**
- k) If a qualified candidate is allotted a seat through the First Admission List and if the offer of admission is accepted, the lower preferences of the candidate, if any, will be automatically cancelled. However, the candidate will remain on the waiting list for all the higher preferences (if any). Qualified candidates, who are not allotted any seat in the First/Second Admission List, will remain on the waiting list in the next round of admission(s). If a qualified candidate fails to accept an admission offer, he/she will not be considered further in the admission process.

Important Note:

- (a) **Verification of Minimum Educational Qualifications (MEQs) and the Eligibility Requirements (ERs) for admission is the prerogative of the Admitting Institute(s) only and the Organizing Institute will not respond to any queries in this regard.**
- (b) **The offer of admission to a candidate will be provisional, subject to the fulfillment of all the requirements by the dates specified.**
- (c) **Candidates should note that being in the Merit List of any test paper neither guarantees nor provides any automatic entitlement for admission. Admissions shall be made in order of merit and depending on the number of seats available at the Admitting Institute(s).**
- (d) **The candidate's finger-print will be captured before he/she takes the JAM 2018 exam. This captured data will be used for verification during the admission process. Hence, the candidate should avoid any coating (ink, mehendi, henna, or tattoo) on their fingertips and have clean fingers on the examination and admission days.**

15. SYLLABI FOR TEST PAPERS

15.1 BIOLOGICAL SCIENCES (BL)

General Biology: Taxonomy of plants and animals; pro-and eukaryotic organisms; cell organelles and their function; multicellular organization; general physiology; energy transformations; internal transport systems of plants and animals; photosynthesis; respiration; regulation of body fluids and excretory mechanisms; reproductive biology; plant and animal hormones and their action; nervous systems; animal behavior; plant and animal diseases; Mendelian genetics and heredity; basics of developmental biology; biology of populations and communities; evolution; basic principles of ecology; genesis and diversity of organisms.

Basics of Biochemistry, Molecular Biology, Biophysics:

Buffers; trace elements in biological systems; enzymes and proteins; vitamins; biological oxidations, photosynthesis; carbohydrates and lipids and their metabolism; digestion and absorption; detoxifying mechanisms; nucleic acids; nucleic acid metabolism; nature of gene and its function; genetic code; synthesis of nucleic acids and proteins; regulation of gene expression; operons.

Structure of biomolecules; intra and intermolecular forces; thermodynamics and kinetics of biological systems; enzyme mechanisms and kinetics; principles of X-ray diffraction; IR- and UV- spectroscopy; analytical and biochemical techniques

Microbiology, Cell Biology and Immunology: Classification of microorganisms and their characterization; nutrient requirement for growth; laboratory techniques in microbiology; pathogenic microorganisms and disease; applied microbiology; viruses and fungi; microbial genetics; cell theory; cell architecture; cell division; types of chromosome structure; biochemical genetics-inborn errors of metabolisms; innate and adaptive immunity, antigen antibodies; principles of processes of development.

Mathematical Sciences: Mathematical functions (algebraic, exponential, trigonometric) and their derivatives (derivatives and integrals of simple functions); permutations and combinations; basic probability and volumetric calculations.

15.2 BIOTECHNOLOGY (BT)

The Biotechnology (BT) test paper comprises of Biology, Chemistry, Mathematics and Physics.

BIOLOGY (10+2+3 level)

General Biology: Taxonomy; Heredity; Genetic variation; Conservation; Principles of ecology; Evolution; Techniques in modern biology.

Biochemistry and Physiology: Carbohydrates; Proteins; Lipids; Nucleic acids; Enzymes; Vitamins; Hormones; Metabolism – Glycolysis, TCA cycle, Oxidative Phosphorylation; Photosynthesis. Nitrogen Fixation, Fertilization and Osmoregulation; Vertebrates-Nervous system; Endocrine system; Vascular system; Immune system; Digestive system and Reproductive System.

Basic Biotechnology: Tissue culture; Application of enzymes; Antigen-antibody interaction; Antibody production; Diagnostic aids.

Molecular Biology: DNA; RNA; Replication; Transcription; Translation; Proteins; Lipids and Membranes; Operon model; Gene transfer.

Cell Biology: Cell cycle; Cytoskeletal elements; Mitochondria; Endoplasmic reticulum; Chloroplast; Golgi apparatus; Signaling.

Microbiology: Isolation; Cultivation; Structural features of virus; Bacteria; Fungi; Protozoa; Pathogenic micro-organisms.

CHEMISTRY (10+2+3 level)

Atomic Structure: Bohr's theory and Schrodinger wave equation; Periodicity in properties; Chemical bonding; Properties of s, p, d and f block elements; Complex formation; Coordination compounds; Chemical equilibria; Chemical thermodynamics (first and second law); Chemical kinetics (zero, first, second and third order reactions); Photochemistry; Electrochemistry; Acid-base concepts; Stereochemistry of carbon compounds; Inductive, electromeric, conjugative effects and resonance; Chemistry of Functional Groups: Hydrocarbons, alkyl halides, alcohols, aldehydes, ketones, carboxylic acids, amines and their derivatives; Aromatic hydrocarbons, halides, nitro and amino compounds, phenols, diazonium salts, carboxylic and sulphonic acids; Mechanism of organic reactions; Soaps and detergents; Synthetic polymers; Biomolecules – amino acids, proteins, nucleic acids, lipids and carbohydrates (polysaccharides); Instrumental techniques – chromatography (TLC, HPLC), electrophoresis, UV-Vis, IR and NMR spectroscopy, mass spectrometry.

MATHEMATICS (10+2 level)

Sets, Relations and Functions, Mathematical Induction, Logarithms, Complex numbers, Linear and Quadratic equations, Sequences and Series, Trigonometry, Cartesian System of Rectangular Coordinates, Straight lines and Family, Circles, Conic Sections, Permutations and Combinations, Binomial Theorem, Exponential and Logarithmic Series, Mathematical Logic, Statistics, Three Dimensional Geometry, Vectors, Matrices and Determinants, Boolean Algebra, Probability, Functions, limits and Continuity, Differentiation, Application of Derivatives, Definite and Indefinite Integrals, Differential Equations.

PHYSICS (10+2 level)

Physical World and Measurement, Elementary Statics and Dynamics, Kinematics, Laws of Motion, Work, Energy and Power, Electrostatics, Current electricity, Magnetic Effects of Current and Magnetism, Electromagnetic Induction and Alternating Current, Electromagnetic waves, Optics, Dual Nature of Matter and Radiations, Atomic Nucleus, Solids and Semiconductor Devices, Principles of Communication, Motion of System of Particles and Rigid Body, Gravitation, Mechanics of Solids and Fluids, Heat and Thermodynamics, Oscillations, Waves.

15.3 CHEMISTRY (CY)

PHYSICAL CHEMISTRY

Basic Mathematical Concepts: Functions; maxima and minima; integrals; ordinary differential equations; vectors and matrices; determinants; elementary statistics and probability theory.

Atomic and Molecular Structure: Fundamental particles; Bohr's theory of hydrogen-like atom; wave-particle duality; uncertainty principle; Schrödinger's wave equation; quantum numbers; shapes of orbitals; Hund's rule and Pauli's exclusion principle; electronic configuration of simple homonuclear diatomic molecules.

Theory of Gases: Equation of state for ideal and non-ideal (van der Waals) gases; Kinetic theory of gases; Maxwell-Boltzmann distribution law; equipartition of energy.

Solid state: Crystals and crystal systems; X-rays; NaCl and KCl structures; close packing; atomic and ionic radii; radius ratio rules; lattice energy; Born-Haber cycle; isomorphism; heat capacity of solids.

Chemical Thermodynamics: Reversible and irreversible processes; first law and its application to ideal and nonideal gases; thermochemistry; second law; entropy and free energy; criteria for spontaneity.

Chemical and Phase Equilibria: Law of mass action; K_p , K_c , K_x and K_n ; effect of temperature on K ; ionic equilibria in solutions; pH and buffer solutions; hydrolysis; solubility product; phase equilibria–phase rule and its application to one-component and two-component systems; colligative properties.

Electrochemistry: Conductance and its applications; transport number; galvanic cells; EMF and free energy; concentration cells with and without transport; polarography; concentration cells with and without transport; Debye-Huckel-Onsager theory of strong electrolytes.

Chemical Kinetics: Reactions of various order; Arrhenius equation; collision theory; transition state theory; chain reactions – normal and branched; enzyme kinetics; photochemical processes; catalysis.

Adsorption: Gibbs adsorption equation; adsorption isotherm; types of adsorption; surface area of adsorbents; surface films on liquids.

Spectroscopy: Beer-Lambert law; fundamental concepts of rotational, vibrational, electronic and magnetic resonance spectroscopy.

ORGANIC CHEMISTRY

Basic Concepts in Organic Chemistry and Stereochemistry: Electronic effects (resonance, inductive, hyperconjugation) and steric effects and its applications

(acid/base property); optical isomerism in compounds with and without any stereocenters (allenes, biphenyls); conformation of acyclic systems (substituted ethane/n-propane/n-butane) and cyclic systems (mono- and di-substituted cyclohexanes).

Organic Reaction Mechanism and Synthetic Applications: Chemistry of reactive intermediates (carbocations, carbanions, free radicals, carbenes, nitrenes, benzynes etc...); Hofmann-Curtius-Lossen rearrangement, Wolff rearrangement, Simmons-Smith reaction, Reimer-Tiemann reaction, Michael reaction, Darzens reaction, Wittig reaction and McMurry reaction; Pinacol-pinacolone, Favorskii, benzilic acid rearrangement, dienone-phenol rearrangement, Baeyer-Villiger reaction; oxidation and reduction reactions in organic chemistry; organometallic reagents in organic synthesis (Grignard, organolithium and organocopper); Diels-Alder, electrocyclic and sigmatropic reactions; functional group inter-conversions and structural problems using chemical reactions.

Qualitative Organic Analysis: Identification of functional groups by chemical tests; elementary UV, IR and ^1H NMR spectroscopic techniques as tools for structural elucidation.

Natural Products Chemistry: Chemistry of alkaloids, steroids, terpenes, carbohydrates, amino acids, peptides and nucleic acids.

Aromatic and Heterocyclic Chemistry: Monocyclic, bicyclic and tricyclic aromatic hydrocarbons, and monocyclic compounds with one hetero atom: synthesis, reactivity and properties.

INORGANIC CHEMISTRY

Periodic Table: Periodic classification of elements and periodicity in properties; general methods of isolation and purification of elements.

Chemical Bonding and Shapes of Compounds: Types of bonding; VSEPR theory and shapes of molecules;

hybridization; dipole moment; ionic solids; structure of NaCl, CsCl, diamond and graphite; lattice energy.

Main Group Elements (s and p blocks): General concepts on group relationships and gradation in properties; structure of electron deficient compounds involving main group elements.

Transition Metals (d block): Characteristics of 3d elements; oxide, hydroxide and salts of first row metals; coordination complexes: structure, isomerism, reaction mechanism and electronic spectra; VB, MO and Crystal Field theoretical approaches for structure, color and magnetic properties of metal complexes; organometallic compounds having ligands with back bonding capabilities such as metal carbonyls, carbenes, nitrosyls and metallocenes; homogenous catalysis.

Bioinorganic Chemistry: Essentials and trace elements of life; basic reactions in the biological systems and the role of metal ions, especially Fe^{2+} , Fe^{3+} , Cu^{2+} and Zn^{2+} ; structure and function of hemoglobin and myoglobin and carbonic anhydrase.

Instrumental Methods of Analysis: Basic principles; instrumentations and simple applications of conductometry, potentiometry and UV-vis spectrophotometry; analysis of water, air and soil samples.

Analytical Chemistry: Principles of qualitative and quantitative analysis; acid-base, oxidation-reduction and complexometric titrations using EDTA; precipitation reactions;

use of indicators; use of organic reagents in inorganic analysis; radioactivity; nuclear reactions; applications of isotopes.

15.4 GEOLOGY (GG)

The Planet Earth: Origin of the Solar System and the Earth; Geosphere and the composition of the Earth; Shape and size of the earth; Earth-moon system; Formation of continents and oceans; Dating rocks and age of the Earth; Volcanism and volcanic landforms; Interior of earth; Earthquakes; Earth's magnetism and gravity, Isostasy; Elements of Plate tectonics; Orogenic cycles.

Geomorphology: Weathering and erosion; Transportation and deposition due to wind, ice, river, sea, and resulting landforms, Structurally controlled landforms.

Structural Geology: Concept of stratum; Contour; Outcrop patterns; Maps and cross sections; Dip and strike; Classification and origin of folds, faults, joints, unconformities, foliations and lineations,; shear zones. Stereographic and equal area projections of planes and lines; computation of true thickness of beds from outcrops and bore-holes.

Palaeontology: Major steps in the evolution of life forms; Fossils; their mode of preservation and utility; Morphological characters, major evolutionary trends and ages of important groups of animals – Brachiopoda, Mollusca, Trilobita, Graptolitoidea, Anthozoa, Echinodermata; Gondwana plant fossils; Elementary idea of vertebrate fossils in India.

Stratigraphy: Principles of stratigraphy; Litho-, chrono- and biostratigraphic classification; distribution and classification of the stratigraphic horizons of India from Archaean to Recent.

Mineralogy: Symmetry and forms in common crystal classes; Physical properties of minerals; Isomorphism and polymorphism, Classification of minerals; Structure of silicates; Mineralogy of common rock-forming minerals; Mode of occurrence of minerals in rocks. Transmitted polarised light microscopy and optical properties of uniaxial and biaxial minerals.

Petrology: Definition and classification of rocks; Igneous rocks-forms of igneous bodies; Crystallization from magma; classification, association and genesis of igneous rocks; Sedimentary rocks – classification, texture and structure; size and shape of sedimentary bodies. Metamorphic rocks – classification, facies, zones and texture. Characteristic mineral assemblages of pelites in the Barrovian zones and mafic rocks in common facies.

Economic Geology: Properties of common economic minerals; General processes of formation of mineral deposits; Physical characters; Mode of occurrence and distribution in India both of metallic and non-metallic mineral deposits; Coal and petroleum occurrences in India.

Applied Geology: Ground Water; Principles of Engineering Geology.

15.5 MATHEMATICS (MA)

Sequences and Series of Real Numbers: Sequence of real numbers, convergence of sequences, bounded and monotone sequences, convergence criteria for sequences of real numbers, Cauchy sequences, subsequences, Bolzano-Weierstrass theorem. Series of real numbers, absolute convergence, tests of convergence for series of positive terms – comparison test, ratio test, root test; Leibniz test for convergence of alternating series.

Functions of One Real Variable: Limit, continuity, intermediate value property, differentiation, Rolle's Theorem, mean value theorem, L'Hospital rule, Taylor's theorem, maxima and minima.

Functions of Two or Three Real Variables: Limit, continuity, partial derivatives, differentiability, maxima and minima.

Integral Calculus: Integration as the inverse process of differentiation, definite integrals and their properties, fundamental theorem of calculus. Double and triple integrals, change of order of integration, calculating surface areas and volumes using double integrals, calculating volumes using triple integrals.

Differential Equations: Ordinary differential equations of the first order of the form $y'=f(x,y)$, Bernoulli's equation, exact differential equations, integrating factor, orthogonal trajectories, homogeneous differential equations, variable separable equations, linear differential equations of second order with constant coefficients, method of variation of parameters, Cauchy-Euler equation.

Vector Calculus: Scalar and vector fields, gradient, divergence, curl, line integrals, surface integrals, Green, Stokes and Gauss theorems.

Group Theory: Groups, subgroups, Abelian groups, non-Abelian groups, cyclic groups, permutation groups, normal subgroups, Lagrange's Theorem for finite groups, group homomorphisms and basic concepts of quotient groups.

Linear Algebra: Finite dimensional vector spaces, linear independence of vectors, basis, dimension, linear transformations, matrix representation, range space, null space, rank-nullity theorem. Rank and inverse of a matrix, determinant, solutions of systems of linear equations, consistency conditions, eigenvalues and eigenvectors for matrices, Cayley-Hamilton theorem.

Real Analysis: Interior points, limit points, open sets, closed sets, bounded sets, connected sets, compact sets, completeness of \mathbb{R} . Power series (of real variable), Taylor's series, radius and interval of convergence, term-wise differentiation and integration of power series.

15.6 MATHEMATICAL STATISTICS (MS)

The Mathematical Statistics (MS) test paper comprises of Mathematics (40% weightage) and Statistics (60%weightage).

Mathematics

Sequences and Series: Convergence of sequences of real numbers, Comparison, root and ratio tests for convergence of series of real numbers.

Differential Calculus: Limits, continuity and differentiability of functions of one and two variables. Rolle's theorem, mean value theorems, Taylor's theorem, indeterminate forms, maxima and minima of functions of one and two variables.

Integral Calculus: Fundamental theorems of integral calculus. Double and triple integrals, applications of definite integrals, arc lengths, areas and volumes.

Matrices: Rank, inverse of a matrix. Systems of linear equations. Linear transformations, eigenvalues and eigenvectors. Cayley-Hamilton theorem, symmetric, skew-symmetric and orthogonal matrices.

Statistics

Probability: Axiomatic definition of probability and properties, conditional probability, multiplication rule. Theorem of total probability. Bayes' theorem and independence of events.

Random Variables: Probability mass function, probability density function and cumulative distribution functions, distribution of a function of a random variable. Mathematical expectation, moments and moment generating function. Chebyshev's inequality.

Standard Distributions: Binomial, negative binomial, geometric, Poisson, hypergeometric, uniform, exponential, gamma, beta and normal distributions. Poisson and normal approximations of a binomial distribution.

Joint Distributions: Joint, marginal and conditional distributions. Distribution of functions of random variables. Joint moment generating function. Product moments, correlation, simple linear regression. Independence of random variables.

Sampling distributions: Chi-square, t and F distributions, and their properties.

Limit Theorems: Weak law of large numbers. Central limit theorem (i.i.d. with finite variance case only).

Estimation: Unbiasedness, consistency and efficiency of estimators, method of moments and method of maximum likelihood. Sufficiency, factorization theorem. Completeness, Rao-Blackwell and Lehmann-Scheffe theorems, uniformly minimum variance unbiased estimators. Rao-Cramer inequality. Confidence intervals for the parameters of univariate normal, two independent normal, and one parameter exponential distributions.

Testing of Hypotheses: Basic concepts, applications of Neyman-Pearson Lemma for testing simple and composite hypotheses. Likelihood ratio tests for parameters of univariate normal distribution.

15.7 PHYSICS (PH)

Mathematical Methods: Calculus of single and multiple variables, partial derivatives, Jacobian, imperfect and perfect differentials, Taylor expansion, Fourier series. Vector algebra, Vector Calculus, Multiple integrals, Divergence theorem, Green's theorem, Stokes' theorem. First order equations and linear second order differential equations with constant coefficients. Matrices and determinants, Algebra of complex numbers.

Mechanics and General Properties of Matter: Newton's laws of motion and applications, Velocity and acceleration in Cartesian, polar and cylindrical coordinate systems, uniformly rotating frame, centrifugal and Coriolis forces, Motion under a central force, Kepler's laws, Gravitational Law and field, Conservative and non-conservative forces. System of particles, Center of mass, equation of motion of the CM, conservation of linear and angular momentum, conservation of energy, variable mass systems. Elastic and inelastic collisions. Rigid body motion, fixed axis rotations, rotation and translation, moments of Inertia and products of Inertia, parallel and perpendicular axes theorem. Principal moments and axes. Kinematics of moving fluids, equation of continuity, Euler's equation, Bernoulli's theorem.

Oscillations, Waves and Optics: Differential equation for simple harmonic oscillator and its general solution. Superposition of two or more simple harmonic oscillators. Lissajous figures. Damped and forced oscillators, resonance. Wave equation, traveling and standing waves in one-dimension. Energy density and energy transmission in waves. Group velocity and phase velocity. Sound waves in media. Doppler Effect. Fermat's Principle. General theory of image formation. Thick lens, thin lens and lens combinations. Interference of light, optical path retardation. Fraunhofer diffraction. Rayleigh criterion and resolving power. Diffraction gratings. Polarization: linear, circular and elliptic polarization. Double refraction and optical rotation.

Electricity and Magnetism: Coulomb's law, Gauss's law. Electric field and potential. Electrostatic boundary conditions, Solution of Laplace's equation for simple cases. Conductors, capacitors, dielectrics, dielectric polarization, volume and surface charges, electrostatic energy. Biot-Savart law, Ampere's law, Faraday's law of electromagnetic induction, Self and mutual inductance. Alternating currents. Simple DC and AC circuits with R, L and C components. Displacement current, Maxwell's equations and plane electromagnetic waves, Poynting's theorem, reflection and refraction at a dielectric interface, transmission and reflection coefficients (normal incidence only). Lorentz Force and motion of charged particles in electric and magnetic fields.

Kinetic theory, Thermodynamics: Elements of Kinetic theory of gases. Velocity distribution and Equipartition of energy. Specific heat of Mono-, di- and tri-atomic gases. Ideal gas, van-der-Waals gas and equation of state. Mean free path. Laws of thermodynamics. Zeroth law and concept of thermal equilibrium. First law and its consequences. Isothermal and adiabatic processes. Reversible, irreversible and quasi-static processes. Second law and entropy. Carnot cycle. Maxwell's thermodynamic relations and simple applications. Thermodynamic potentials and their applications. Phase transitions and Clausius-Clapeyron equation. Ideas of ensembles, Maxwell-Boltzmann, Fermi-Dirac and Bose-Einstein distributions.

Modern Physics: Inertial frames and Galilean invariance. Postulates of special relativity. Lorentz transformations. Length contraction, time dilation. Relativistic velocity addition theorem, mass energy equivalence. Blackbody radiation, photoelectric effect, Compton effect, Bohr's atomic model, X-rays. Wave-particle duality, Uncertainty principle, the superposition principle, calculation of expectation values, Schrödinger equation and its solution for one, two and three dimensional boxes. Solution of Schrödinger equation for the one dimensional harmonic oscillator. Reflection and transmission at a step potential, Pauli exclusion principle. Structure of atomic nucleus, mass and binding energy. Radioactivity and its applications. Laws of radioactive decay.

Solid State Physics, Devices and Electronics: Crystal structure, Bravais lattices and basis. Miller indices. X-ray diffraction and Bragg's law; Intrinsic and extrinsic semiconductors, variation of resistivity with temperature. Fermi level. p-n junction diode, I-V characteristics, Zener diode and its applications, BJT: characteristics in CB, CE, CC modes. Single stage amplifier, two stage R-C coupled amplifiers. Simple Oscillators: Barkhausen condition, sinusoidal oscillators. OPAMP and applications: Inverting and non-inverting amplifier. Boolean algebra: Binary number systems; conversion from one system to another system; binary addition and subtraction. Logic Gates AND, OR, NOT, NAND, NOR exclusive OR; Truth tables; combination of gates; de Morgan's theorem.

Appendix-I: Academic Programmes (and their Codes) Covered under JAM 2018 at Various Admitting Institutes for JAM 2018 Qualified Candidates

NOTE:

The number of seats is subject to change.

OBC refers to OBC(Non-Creamy Layer).

The following is the Explanation of Entries in Cells (**Appendix – I**)

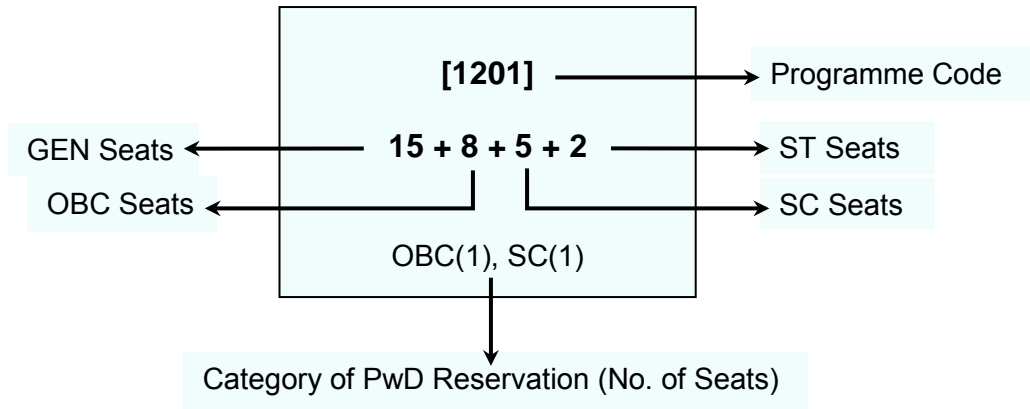

1. IIT Bombay:

M.Sc. (4 semesters)	Applied Geology	Applied Geophysics	Applied Statistics and Informatics	Biotechnology	Chemistry	Mathematics	Physics
[Programme code] Seats Available	[1201] 15+8+5+2 GEN(1) SC(1)	[1202] 8+5+2+1 GEN(1)	[1203] 19+10+5+3 SC(1)	[1204] 14+8+4+2 GEN(1)	[1205] 23+12+7+3 GEN(1), OBC(1)	[1206] 15+8+5+2 GEN(1), OBC(1)	[1207] 24+12+7+5 OBC(1), ST(1)
Paper Code(s)	GG	PH	MS	BT	CY	MA	PH

M.Sc. – Ph.D. dual degree	Environmental Science and Engineering	Operations Research
[Programme code] Seats Available	[1213] 5+3+1+1 GEN(1)	[1214] 6+3+2+1 GEN(1)
Paper Code(s)	BT,CY,MA,PH	MA,MS

2. IIT Delhi:

M.Sc. (4 semesters)	Chemistry	Mathematics	Physics
[Programme code] Seats Available	[1301] 27+15+8+4 GN(1), OBC (1)	[1302] 27+15+8+4 GEN(1), OBC (1), ST(1)	[1303] 27+15+8+4 GEN(1), OBC(1), SC(1)
Paper Code(s)	CY	MA	PH

3. IIT Guwahati:

M.Sc. (4 semesters)	Chemistry	Mathematics and Computing	Physics
[Programme code] Seats Available	[1401] 24+13+7+4 GEN (2)	[1402] 24+13+7+4 GEN (1), OBC (1), SC(1)	[1403] 24+13+7+4 GEN (1), OBC (1)
Paper Code(s)	CY	MA	PH

4. IIT Kanpur:

M.Sc. (4 semesters)	Chemistry	Mathematics	Physics	Statistics
[Programme code] Seats Available	[1501] 20+11+6+3 GEN (1), ST(1)	[1502] 20+11+6+3 GEN(1), OBC (1)	[1503] 15+8+5+2 GEN(1),SC (1)	[1504] 25+14+7+4 GEN(1), OBC(1)
Paper Code(s)	CY	MA	PH	MS

M.Sc.- Ph.D. dual degree	Physics
[Programme code] Seats Available	[1505] 8+4+2+1 GEN(1)
Paper Code(s)	PH

5. IIT Kharagpur:

Joint M.Sc.- Ph.D.	Chemistry	Geology	Mathematics	Physics	Geophysics
[Programme code] Seats Available	[1601] 23+13+6+4 GEN(1), ST(1)	[1602] 15+8+5+2 GEN(1), SC(1)	[1603] 15+8+5+2 GEN(1), OBC(1)	[1604] 24+12+7+3 GEN(1), OBC(1)	[1605] GG 6+3+2+1 [1605] PH 6+3+2+1 GEN (1)
Paper Code(s)	CY	GG	MA	PH	GG,PH

6. IIT Madras:

M.Sc. (4 semesters)	Chemistry	Mathematics	Physics
[Programme code] Seats Available	[1701] 27+15+8+4 GEN(1), OBC(1), ST(1)	[1702] 27+15+8+4 GEN(1), OBC(1), ST(1)	[1703] 22+12+7+3 GEN(1), SC(1)
Paper Code(s)	CY	MA	PH

7. IIT Roorkee:

M.Sc. (4 semesters)	Applied Geology	Biotechnology	Chemistry	Mathematics	Physics	Economics
[Programme code] Seats Available	[1801] 8+4+2+1	[1802] 18+10+6+3 GEN(1), OBC(1), ST(1)	[1803] 23+12+7+3 GEN(1), OBC(1), SC(1)	[1804] 15+8+5+2 GEN(1)	[1805] 12+7+4+2 GEN(1)	[1806] MA 15+8+5+2 GEN(1)
Paper Code(s)	GG	BT	CY	MA	PH	MA

8. IIT Bhubaneswar:

Joint M.Sc.-Ph.D.	Chemistry	Mathematics	Physics	Geology	Atmosphere and Ocean Sciences
[Programme code] Seats Available	[1901] 10+5+3+2 GEN(1)	[1902] 10+5+3+2 GEN(1)	[1903] 10+5+3+2 GEN(1)	[1904] 10+5+3+2 OBC(1)	[1905] CY: 1+2+1+0 GEN(1) GG: 2+1+1+0 MA: 2+2+0+0 MS: 2+1+1+0 PH: 3+1+0+0
Paper Code(s)	CY	MA	PH	GG	CY,GG,MA,MS,PH

9. IIT Gandhinagar:

M.Sc. (4 semesters)	Chemistry	Mathematics	Physics
[Programme code] Seats Available	[2001] 10+6+3+1 GEN(1), SC (1)	[2002] 15+8+4+3 SC (1)	[2003] 14+8+5+3 GEN(1), SC (1)
Paper Code(s)	CY	MA	PH

10. IIT Hyderabad:

M.Sc. (4 semesters)	Chemistry	Mathematics/ Mathematics and Computing	Physics
[Programme code] Seats Available	[2101] 20+11+6+3 GEN (1)	[2102] 8+4+2+1 ST (1)	[2103] 10+5+3+2 GEN (1), ST (1)
Paper Code(s)	CY	MA	PH

11. IIT Indore:

M.Sc. (4 semesters)	Chemistry	Physics	Mathematics	Biotechnology	Astronomy
[Programme code] Seats Available	[2201] 12+6+4+2 GEN(1)	[2202] 12+6+4+2 GEN(1)	[2203] 6+3+2+1 GEN(1)	[2204] 6+3+2+1 GEN(1)	[2205] 6+3+2+1
Paper Code(s)	CY	PH	MA	BT	PH

12. IIT Ropar:

M.Sc. (4 semesters)	Mathematics	Chemistry	Physics
[Programme code] Seats Available	[2301] 12+5+4+2 GEN(1), OBC(1)	[2302] 13+6+3+2 SC(1)	[2303] 13+6+4+1 ST(1)
Paper Code(s)	MA	CY	PH

13. IIT Jodhpur:

M.Sc. (4 semesters)	Chemistry	Mathematics	Physics
[Programme code] Seats Available	[2401] 10+6+3+1	[2402] 10+6+3+1	[2403] 10+6+3+1
Paper Code(s)	CY	MA	PH

14. IIT Patna:

M.Sc. (4 semesters)	Chemistry	Mathematics	Physics
[Programme code] Seats Available	[2501] 7+4+2+1 GEN(1)	[2502] 7+4+2+1 GEN(1)	[2503] 7+4+2+1 GEN(1)
Paper Code(s)	CY	MA	PH

15. IIT (ISM) Dhanbad:

M.Sc. (4 semesters)	Chemistry	Mathematics and Computing	Physics
[Programme code] Seats Available	[2601] 27+15+8+4 GEN(2),OBC(1)	[2602] 22+12+7+3 GEN(1),SC(1)	[2603] 22+12+7+3 GEN(1),SC(1)
Paper Code(s)	CY	MA	PH

M.Sc.(Tech) (6 semesters)	Applied Geology	Applied Geophysics
[Programme code] Seats Available	[2604] 27+15+8+4 GEN(1),OBC(1),ST(1)	[2605] 22+12+7+3 GEN(1),OBC(1)
Paper Code(s)	GG	PH

16. Other Admitting Institutes:

For programmes listed in Table 9, admissions will not be directly based on the JAM 2018 score. However, to get admitted into these programmes, a candidate must qualify JAM 2018 and then apply separately to the concerned Institutes.

Table 9: Other Admitting Institutes and Programmes

S. No	Programme	Admitting Institute	JAM Test Papers
1	Integrated PhD in Biological Sciences	IISc Bangalore	BL, BT
2	Integrated PhD in Chemical Sciences	IISc Bangalore	BL, CY, PH
3	Integrated PhD in Mathematical Sciences	IISc Bangalore	MA, MS
4	Integrated PhD in Physical Sciences	IISc Bangalore	PH
5	M.Sc-PhD Dual Degree in Energy	IIT Bombay	CY, MA, PH

17. CCMN 2018 (Counseling Body for Admission to NITs & CFTIs) will admit candidates through qualified JAM 2018 scores. Refer web page of CCMN2018 (<http://www.ccmn.in>) for further information about these Institutes

Appendix-II: Test Papers, corresponding Academic Programmes offered by the Admitting Institutes and their Minimum Educational Qualifications for Admission

Test Paper (Test paper code)	Academic Programme(s)	Institute(s)	Minimum Educational Qualification(s) for Admission	
			Essential subjects in Bachelor's Degree along with minimum duration	Essential subjects at (10+2) level
Biotechnology (BT)	M.Sc. Biotechnology	IITB, IITI, IITR	Any Branch/ Subject	Mathematics
	M.Sc.- Ph.D. Dual Degree in Environmental Science and Engineering	IITB	Any one of Biology, Biotechnology, Chemistry, Mathematics and Physics for two years/four semesters, and any one of the other four subjects for at least one year/two semesters	
Chemistry (CY)	M.Sc. Chemistry	IITB, IITD, IITG, IITGN, IITH, IITI, IITJ, IITK, IITM, IITP, IITR, IITRPR, IITISM	Chemistry for three years/six semesters	Mathematics
	Joint M.Sc.- Ph.D. in Chemistry	IITBBS, IITKGP		
	M.Sc.- Ph.D. Dual Degree in Environmental Science and Engineering	IITB	Any one of Biology, Biotechnology, Chemistry, Mathematics and Physics for two years/four semesters, and any one of the other four subjects for at least one year/two semesters	Mathematics
	Joint M.Sc.- Ph.D. in Atmosphere and Ocean Sciences	IITBBS	Mathematics and Physics with any one of these subjects among Chemistry, Computer Science, Computer Application, Geology and Statistics	No Restrictions
Geology (GG)	M.Sc. Applied Geology	IITB, IITR	Geology for three years/six semesters and any two subjects among Mathematics, Physics, Chemistry and Biological Science	Mathematics
	Joint M.Sc.- Ph.D. in Geophysics	IITKGP	Geology as a subject for three years/six semesters and any two subjects among Mathematics, Physics and Chemistry	
	Joint M.Sc.- Ph.D. in Geology	IITKGP, IITBBS		
	Joint M.Sc.- Ph.D. in Atmosphere and Ocean Sciences	IITBBS	Mathematics and Physics and any one of these subjects among Chemistry, Computer Science, Computer Application, Geology and Statistics	No Restrictions
	M.Sc.(Tech) in Applied Geology *	IITISM	B.Sc degree (3 year) with Geology as Honours/ Major/ Main/Equivalent subject and any 2 subsidiary subjects from Mathematics, Physics and Chemistry.	Mathematics

Test Paper (Test paper code)	Academic Programme(s)	Institute(s)	Minimum Educational Qualification(s) for Admission	
			Essential subjects in Bachelor's Degree along with minimum duration	Essential subjects at (10+2) level
Mathematics (MA)	M.Sc. in Economics	IITR	Mathematics as one of the core subjects	No Restrictions
	M.Sc. Mathematics	IITB, IITD, IITGN, IITI, IITJ, IITK, IITM, IITP, IITR, IITRPR	Mathematics for at least two years/four semesters	
	M.Sc. Mathematics/ Mathematics and Computing	IITH, IITISM		
	M.Sc. Mathematics and Computing	IITG		
	Joint M.Sc.- Ph.D. in Mathematics	IITBBS, IITKGP	Mathematics/ Statistics as a subject for at least two years/four semesters.	
	M.Sc.- Ph.D. Dual Degree in Operations Research	IITB		
	M.Sc.- Ph.D. Dual Degree in Environmental Science and Engineering	IITB	Any one of Biology, Biotechnology, Chemistry, Mathematics and Physics for two years/four semesters, and any one of the other four subjects for at least one year/two semesters.	Mathematics
Joint M.Sc.- Ph.D. in Atmosphere and Ocean Sciences	IITBBS	Mathematics and Physics and any one of these subjects among Chemistry, Computer Science, Computer Application, Geology and Statistics	No Restrictions	
Mathematical Statistics (MS)	M.Sc. Applied Statistics and Informatics	IITB	Mathematics or Statistics for at least two years/ four semesters	No Restrictions
	M.Sc.- Ph.D. Dual Degree in Operations Research	IITB		
	M.Sc. Statistics	IITK	Statistics for at least two years/ four semesters	
	Joint M.Sc.- Ph.D. in Atmosphere and Ocean Sciences	IITBBS	Mathematics and Physics and any one of these subjects among Chemistry, Computer Science, Computer Application, Geology and Statistics	

Test Paper (Test paper code)	Academic Programme(s)	Institute(s)	Minimum Educational Qualification(s) for Admission		
			Essential subjects in Bachelor's Degree along with minimum duration	Essential subjects at (10+2) level	
Physics (PH)	M.Sc. Physics	IITB, IITD, IITG, IITGN, IITH, IITI, IITJ, IITK, IITM, IITP, IITR, IITRPR, IITISM	Physics for at least two years/four semesters and Mathematics for at least one year/two semesters	No Restrictions	
	Joint M.Sc.- Ph.D. in Physics	IITBBS, IITKGP			
	M.Sc.- Ph.D. Dual Degree in Physics	IITK			
	M.Sc. Applied Geophysics	IITB	Physics and Mathematics/Mathematical Physics for two years/four semesters and at least one of them as subject for three years/six semesters		
	M.Sc. Astronomy	IITI	Physics/ Mathematics / Computer Science Engineering, Electrical Engineering/ Mechanical Engineering		
	Joint M.Sc.- Ph.D. in Atmosphere and Ocean Sciences	IITBBS	Mathematics and Physics and any one of these subjects among Chemistry, Computer Science, Computer Application, Geology and Statistics		
	Joint M.Sc.- Ph.D. in Geophysics	IITKGP	Geology as a subject for three years/six semesters and any two subjects among Mathematics, Physics and Chemistry		
	M.Sc.- Ph.D. Dual Degree in Environmental Science and Engineering	IITB	Any one of Biology, Biotechnology, Chemistry, Mathematics and Physics for two years/four semesters, and any one of the other four subjects for at least one year/two semesters		Mathematics
	M.Sc.(Tech) in Applied Geophysics	IITISM	B.Sc Degree (3 yr.) with Physics as Honours/ Major/ Main/ Equivalent subject, Mathematics as a subsidiary subject for 2 years/4 semesters and another subsidiary subject from Chemistry, Geology, Electronics, and Statistics for 1 year/ 2 semesters.		No Restriction

- * Medical Criteria: a) Applicants with color blindness and/or Uni-ocularity are not eligible.
b) To do fieldwork, persons with disability (PwD) category candidates should be able to walk in the field without assistance /escort (on-road and/or off-road conditions.)

Appendix–III: EXAMINATION CITIES / TOWNS FOR JAM 2018

1. IISc Bangalore Zone

Test City	Code
Bengaluru	101
Hubli	102
Hyderabad	103
Kannur	104
Kozhikode	105
Mangalore	106
Palakkad	107
Thrissur	108

3. IIT Delhi Zone

Test City	Code
Faridabad	301
Ghaziabad	302
Greater Noida	303
Gurugram	304
Hisar	305
Indore	306
Jaipur	307
Jammu	308
Jodhpur	309
New Delhi	310

5. IIT Kanpur Zone

Test City	Code
Agra	501
Allahabad	502
Bareilly	503
Bhopal	504
Kanpur	505
Lucknow	506
Varanasi	507

7. IIT Madras Zone

Test City	Code
Chennai	701
Coimbatore	702
Ernakulam	703
Kollam	704
Kottayam	705
Madurai	706
Thiruvananthapuram	707
Tiruchirapalli	708
Tirunelveli	709
Warangal	710

2. IIT Bombay Zone

Test City	Code
Ahmedabad	201
Goa	202
Mumbai	203
Nagpur	204
Nanded	205
Nasik	206
Pune	207
Vadodara	208

4. IIT Guwahati Zone

Test City	Code
Asansol - Durgapur	401
Dhanbad	402
Dibrugarh	403
Guwahati	404
Jorhat	405
Kalyani	406
Patna	407
Siliguri	408

6. IIT Kharagpur Zone

Test City	Code
Bhubaneswar	601
Kharagpur	602
Kolkata	603
Raipur	604
Ranchi	605
Vijayawada	606
Visakhapatnam	607

8. IIT Roorkee Zone

Test City	Code
Dehradun	801
Jalandhar	802
Kurukshetra	803
Mohali	804
Noida	805
Moradabad	806
Roorkee	807

Appendix-IV

AUTHORITIES WHO MAY ISSUE SC / ST / OBC (NON-CREAMY LAYER) CERTIFICATES

SC/ST/OBC (Non-Creamy Layer) candidates should submit a certificate issued by any of the following authorities:

District Magistrate / Additional District Magistrate / Collector / Deputy Commissioner / Additional Deputy Commissioner / Deputy Collector / 1st Class Stipendary Magistrate / Sub-Divisional Magistrate / Taluka Magistrate / Executive Magistrate / Extra Assistant Commissioner (not below the rank of 1st class Stipendary Magistrate) / Chief Presidency Magistrate / Additional Chief Presidency Magistrate / Presidency Magistrate / Revenue Officer not below the rank of Tahsildar / Sub-Divisional Officer of the area where the candidate and / or his / her family normally resides / Administrator / Secretary to Administrator / Development Officer (Lakshadweep Island).

(Certificate issued by any other authority will be rejected)

Appendix-V: Proforma for Other Backward Class (Non-Creamy Layer) Certificate

**(FORM OF CERTIFICATE TO BE PRODUCED BY OTHER BACKWARD CLASSES
APPLYING FOR ADMISSIONS TO CENTRAL EDUCATIONAL INSTITUTIONS (CEIs)
UNDER THE GOVERNMENT OF INDIA)**

This is to certify that Shri/Smt./Kumari _____
Son/Daughter of _____ of Village/Town
_____ in _____ District/Division
_____ in the State/Union Territory
_____ belongs to the
_____ Community which is recognized as a
backward class under the Government of India, Ministry of Social Justice and
Empowerment's Resolution No. _____
dated _____*.

Shri/Smt./Kumari _____ and/or his/her family
ordinarily reside(s) in the _____ District/Division of
_____ State/Union Territory. This is also to certify that
he/she **does not belong to the persons/sections (Creamy Layer)** mentioned in Column
3 of the Schedule to the Government of India, Department of Personnel & Training O.M.
No. 36012/22/93-Estt.(SCT) dated 08.09.1993 as amended from time to time.

Dated:

District Magistrate,
Deputy Commissioner, etc.

Seal

* - The authority issuing the certificate may have to mention the details of Resolution (Number and Date) of Government of India, in which the caste of the candidate is mentioned as OBC.

NOTE:

- (a) The term "Ordinarily" used here will have the same meaning as in Section 20 of the Representation of the People Act, 1950.
- (b) The authorities competent to issue Caste Certificates are indicated below:
- District Magistrate / Additional Magistrate / Collector / Deputy Commissioner / Additional Deputy Commissioner / Deputy Collector / Ist Class Stipendiary Magistrate / Sub-Divisional Magistrate / Taluka Magistrate / Executive Magistrate / Extra Assistant Commissioner (not below the rank of 1st Class Stipendiary Magistrate).
 - Chief Presidency Magistrate / Additional Chief Presidency Magistrate / Presidency Magistrate.
 - Revenue Officer not below the rank of Tehsildar and
 - Sub-Divisional Officer of the area where the candidate and / or his/her family resides.

The date of issue of OBC (NCL) certificate should be after March 31, 2017

IMPORTANT DATES FOR JAM 2018

Commencement of ONLINE Registration and Application on JAM 2018 Website	September 05, 2017 (Tuesday)
Last Date for Online Application Submission and Uploading of Documents on the Website	October 10, 2017 (Tuesday)
Last Date for Payment of Application Fee through Online process	October 10, 2017 (Tuesday)
Date of JAM 2018 Examination	February 11, 2018 (Sunday)
Announcement of the Results of JAM 2018	March 20, 2018 (Tuesday)
Submission of Application Form for Admission on the JAM 2018 Website	April 03 - 17, 2018
Last Date for receipt of request for change of category in proper format/ rectification of defective documents at IIT Bombay	May 7, 2018 (Monday)
Declaration of First Admission List	May 22, 2018 (Tuesday)
Declaration of Second Admission List	June 12, 2018 (Tuesday)
Declaration of Third and Final Admission List	June 29, 2018 (Friday)
Closure of Admissions through JAM 2018	July 05, 2018 (Thursday)

Note: Information regarding JAM 2018 will be sent through SMS also. Hence, you are advised to keep JAM 2018 Sender Id unblocked.

CONTACT ADDRESSES OF JAM OFFICES

Institute	Website	E-mail	Phone / Fax
IISc Bangalore	http://gate.iisc.ernet.in/jam	jam@gate.iisc.ernet.in	(080) 22932392 / 23601227
IIT Bombay	http://www.gate.iitb.ac.in/jam2018	jam@iitb.ac.in	(022) 25767022 / 25722674
IIT Delhi	http://jam.iitd.ac.in	chrjam@admin.iitd.ac.in	(011) 26591749 / 26581579
IIT Guwahati	http://www.iitg.ernet.in/jam	jam@iitg.ernet.in	(0361) 2582751 / 2582755
IIT Kanpur	http://gate.iitk.ac.in/jam	jam@iitk.ac.in	(0512) 2597412 / 2597304
IIT Kharagpur	http://jam.iitkgp.ac.in	gate@adm.iitkgp.ernet.in	(03222) 282091 / 278244
IIT Madras	http://jam.iitm.ac.in/	jam@iitm.ac.in	(044) 22578200 / 22578204
IIT Roorkee	http://www.iitr.ac.in/jam	jam@iitr.ac.in	(01332) 284531 / 285707

IMPORTANT NOTE

- In all matters concerning JAM 2018, the decision of the **Organizing Institute** or the **Organizing Chairperson, JAM 2018** will be final and binding on all the applicants.
- Although JAM 2018 is held at different centres across country, **Indian Institute of Technology Bombay** is the **Organizing Institute**, and has the overall responsibility of conducting JAM 2018. In case of any claims or disputes arising in respect of JAM 2018, it is hereby made absolutely clear that the Bombay High Court alone shall have the exclusive jurisdiction to entertain and settle any such disputes and claims.

Information contained in this brochure is correct as on 28th September 2017. There may be changes in future due to unavoidable reasons. As and when any change happens, it will be notified on JAM 2018 website <http://jam.iitb.ac.in>

Organizing Institute

INDIAN INSTITUTE OF TECHNOLOGY BOMBAY



JAM 2018 Website:
<http://jam.iitb.ac.in>

